

Mathematics test

Paper 2

Calculator allowed

Please read this page, but do not open your booklet until your teacher tells you to start. Write your name and the name of your school in the spaces below.

First name _____

Last name _____

School _____

Remember

- The test is 1 hour long.
- You may use a calculator for any question in this test.
- You will need: pen, pencil, rubber, ruler, a pair of compasses and a scientific or graphic calculator.
- Some formulae you might need are on page 2.
- This test starts with easier questions.
- Try to answer all the questions.
- Write all your answers and working on the test paper – do not use any rough paper. Marks may be awarded for working.
- Check your work carefully.
- Ask your teacher if you are not sure what to do.

For marker's
use only

Total marks

Borderline check

| |
|--|
| |
| |

Instructions

Answers



This means write down your answer or show your working and write down your answer.

Calculators



You **may** use a calculator to answer any question in this test.

Formulae

You might need to use these formulae

Trapezium

$$\text{Area} = \frac{1}{2}(a + b)h$$

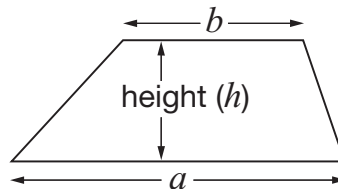

Prism

area of cross-section

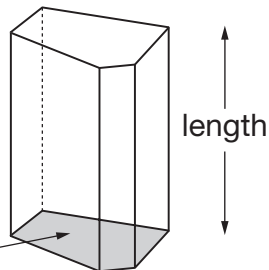

$$\text{Volume} = \text{area of cross-section} \times \text{length}$$

1. I buy **12 packets** of cat food in a box.

The table shows the different varieties in the box.

| Variety | Number of packets |
|---------|-------------------|
| Cod | 3 |
| Salmon | 3 |
| Trout | 3 |
| Tuna | 3 |

- (a) I am going to take out a packet at random from the box.

What is the **probability** that it will be **cod**?



1 mark

- (b) My cat eats **all** the packets of **cod**.

I am going to take out a packet at random from the ones left in the box.

What is the **probability** that it will be **salmon**?



1 mark

- (c) A different type of cat food has **10 packets** in a box.

The probability that the variety is chicken is **0.7**

What is the probability that the variety is **not** chicken?



1 mark



2. Wine gums are sweets that are made in different colours.

Pupils tested whether people can taste the difference between black wine gums and other wine gums.

The percentage bar charts show three pupils' results.

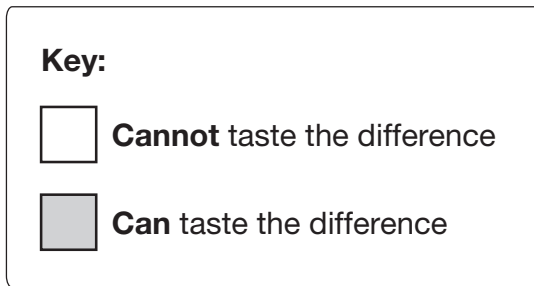

Ravi's results

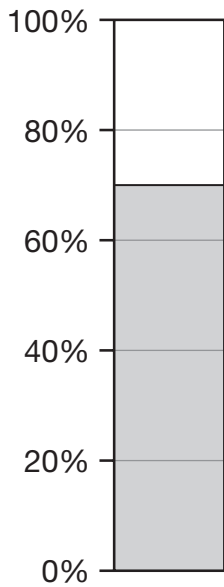

Ravi asked
50 people

Sita's results

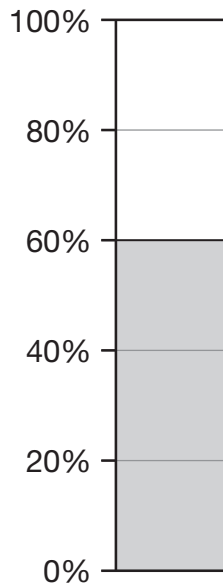

Sita asked
100 people

Tina's results

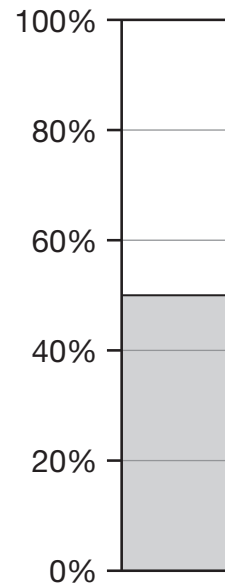

Tina asked
200 people

(a) Complete the table.

| | Number of people who were tested | Number of people who can taste the difference | Number of people who cannot taste the difference |
|--|----------------------------------|--|---|
|  Ravi | 50 | | |
| Sita | 100 | | |
| Tina | 200 | | |

3 marks

(b) Explain why **Tina's** results are likely to be **more reliable** than Ravi's or Sita's.



1 mark

3. Look at the three expressions below.

$$8 + k$$

$$3k$$

$$k^2$$

When $k = 10$, what is the value of each expression?



$8 + k = \underline{\hspace{2cm}}$

$3k = \underline{\hspace{2cm}}$

$k^2 = \underline{\hspace{2cm}}$

2 marks



4. Some statements in the table are true. Some are false.

Beside each statement, write **true** or **false**.

For **true** statements you must **draw an example**.

The first one is done for you.

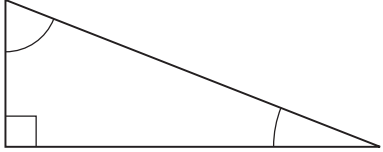
| Statement | Write true or false . If true, draw an example. |
|--|---|
| Some triangles have one right angle and two acute angles. | true  |
| Some triangles have three right angles. | |
| Some triangles have three acute angles. | |
| Some triangles have one obtuse angle and two acute angles. | |
| Some triangles have two obtuse angles and one acute angle. | |

3 marks

5. A shop sells toilet rolls.
You can buy them in packs of 9 or packs of 6

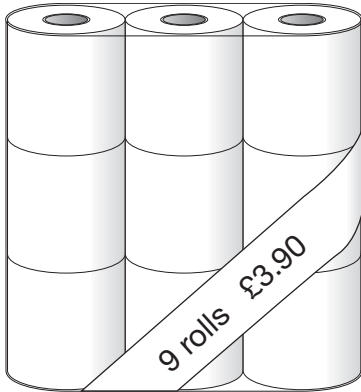

Pack of 9 toilet rolls
£3.90

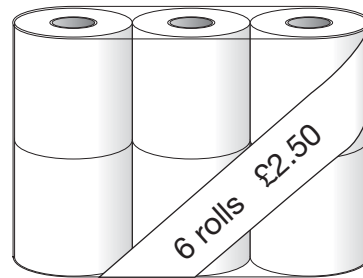

Pack of 6 toilet rolls
£2.50

Which pack gives you better value for money?

You **must** show your working.



3 marks



6. Three different types of woodpecker live in Britain.

The pictogram shows information about the numbers of each type.

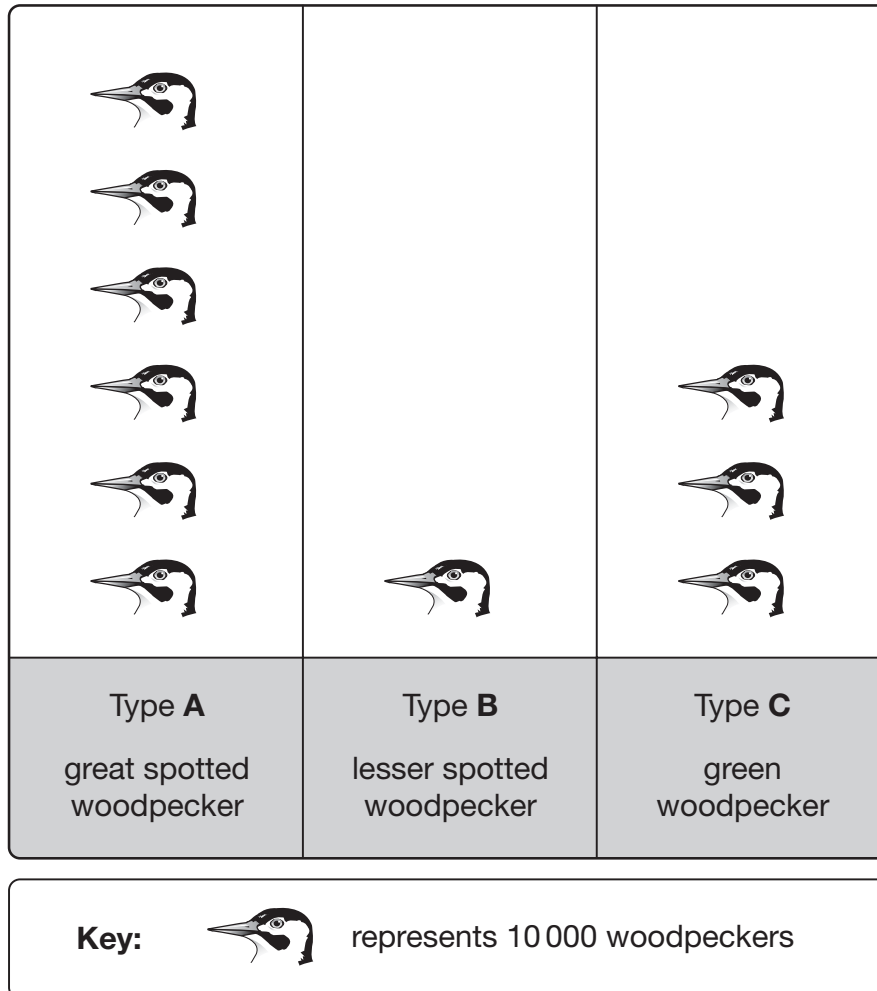

(a) Complete the table below to show the **percentages** of each type of woodpecker.

| | Type A | Type B | Type C |
|---|---------|---------|---------|
|  | _____ % | _____ % | _____ % |

1 mark

(b) The ratio of **type A : type B** woodpeckers is 6 : 1

What is the ratio of **type B : type C** woodpeckers?

 _____ : _____

_____ 1 mark

7. Write the missing numbers in the boxes.



120mm is the same as cm

_____ 1 mark

120cm is the same as m

_____ 1 mark

120m is the same as km

_____ 1 mark



8. Look at the diagram, made from four straight lines.
The lines marked with arrows are parallel.

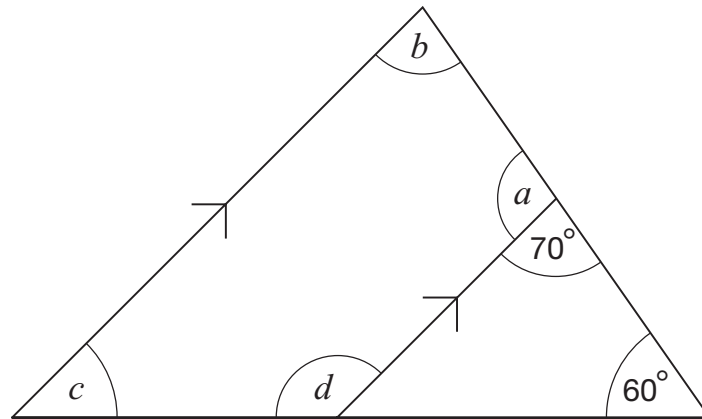

Not drawn
accurately

Work out the sizes of the angles marked with letters.



$$a = \underline{\hspace{2cm}}^\circ$$

$$b = \underline{\hspace{2cm}}^\circ$$

$$c = \underline{\hspace{2cm}}^\circ$$

$$d = \underline{\hspace{2cm}}^\circ$$

3 marks

9. Look at this equation.

$$3a + 20 = 4a + k$$

(a) If $a = 15$, find the value of k



$k =$ _____

_____ 1 mark

(b) If $a = -15$, find the value of k





$k =$ _____

_____ 1 mark

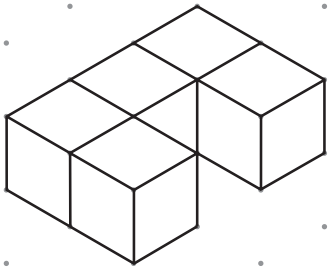
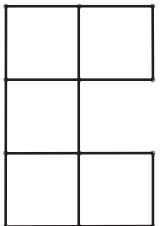
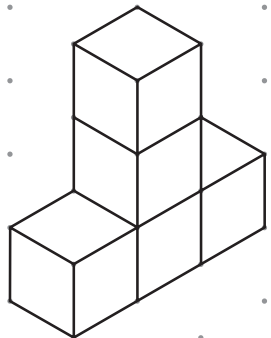

10. Each shape below is made from **five cubes** that are joined together.
Complete the missing diagrams below.

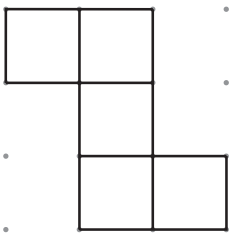
| Shape drawn on an isometric grid | View from above of the shape drawn on a square grid |
|---|--|
|  |  |
|  |  |
|  |  |

1 mark

2 marks

11. Look at these pairs of number sequences.

The second sequence is formed from the first sequence by adding a number or multiplying by a number.

Work out the missing n th terms.

(a) $5, 9, 13, 17, \dots$ n th term is $4n + 1$

$6, 10, 14, 18, \dots$



n th term is _____

1 mark

(b) $12, 18, 24, 30, \dots$ n th term is $6n + 6$

$6, 9, 12, 15, \dots$



n th term is _____

1 mark

(c) $2, 7, 12, 17, \dots$ n th term is $5n - 3$

$4, 14, 24, 34, \dots$



n th term is _____

1 mark



12. Look at the square grids.

Each diagram shows an enlargement of scale factor 2

The **centre** of this enlargement is marked with a cross.

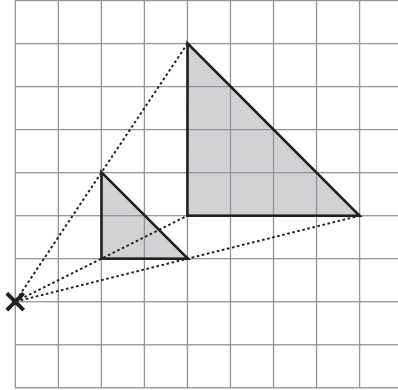

Where is the centre of enlargement in these diagrams?

Mark each one with a cross.

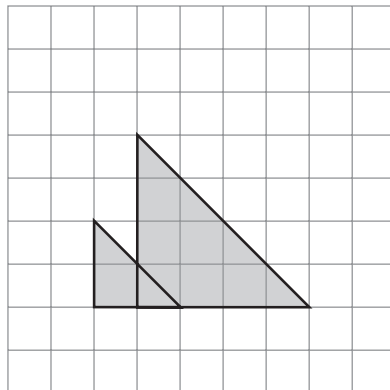

1 mark

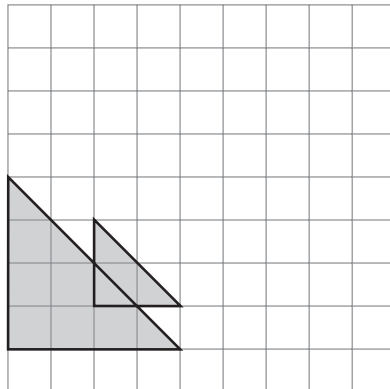

1 mark

13. Multiply out these expressions.
Write your answers as simply as possible.

$$5(x + 2) + 3(7 + x)$$



2 marks

$$(x + 2)(x + 5)$$



2 marks



14. Kate asked people if they read a daily newspaper.

Then she wrote this table to show her results.

| | |
|-----|------------------|
| No | 80 people = 40% |
| Yes | 126 people = 60% |

The values in the table **cannot** all be correct.

- (a) The error could be in the number of people.

Complete each table to show what the correct numbers could be.

| | |
|-----|--------------------|
| No | 80 people = 40% |
| Yes | _____ people = 60% |

1 mark

| | |
|-----|--------------------|
| No | _____ people = 40% |
| Yes | 126 people = 60% |

1 mark

(b) The error could be in the percentages.

Complete the table with the correct percentages.



| | |
|-----|----------------------|
| No | 80 people = _____ % |
| Yes | 126 people = _____ % |

2 marks



15. The graph shows information about the diameters and heights of a sample of three types of tomato.

The dotted lines on the graph can be used to decide which type of tomato each point is likely to represent.

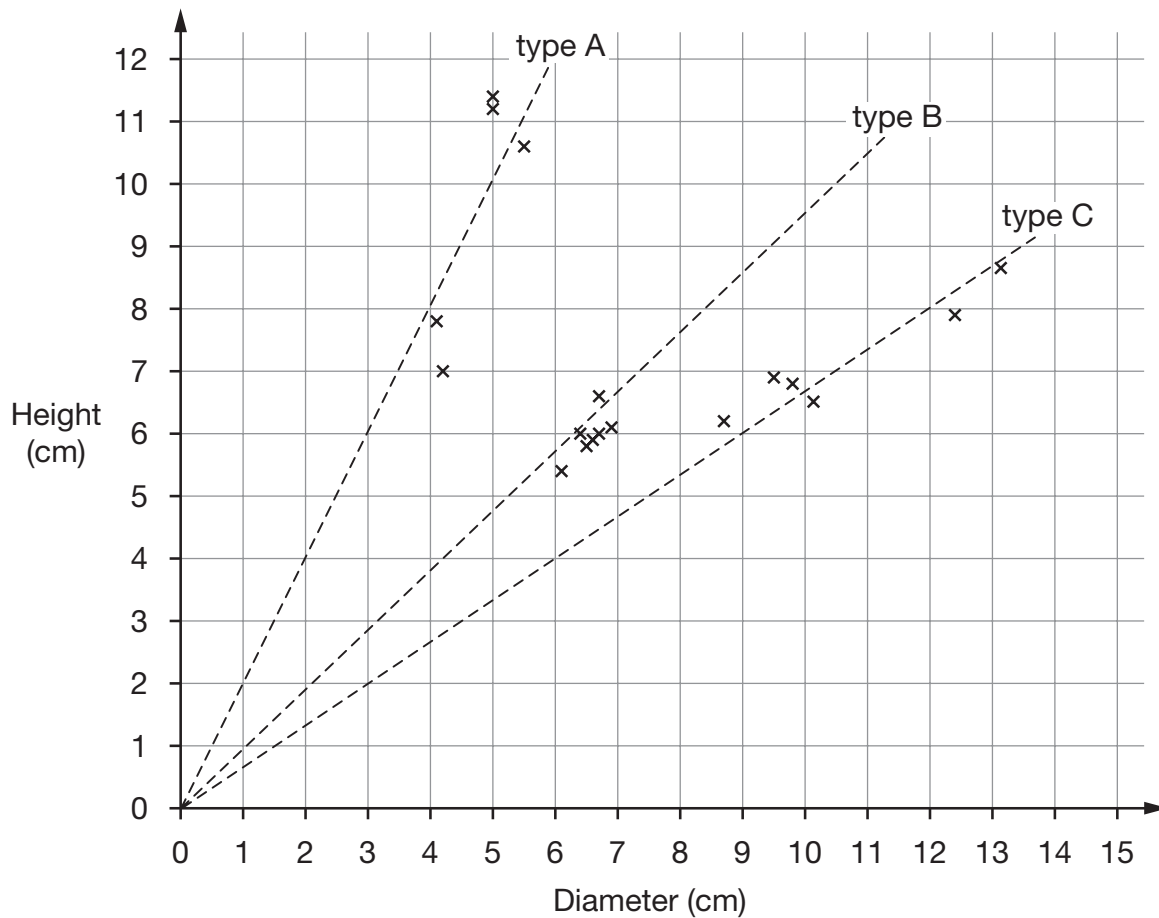
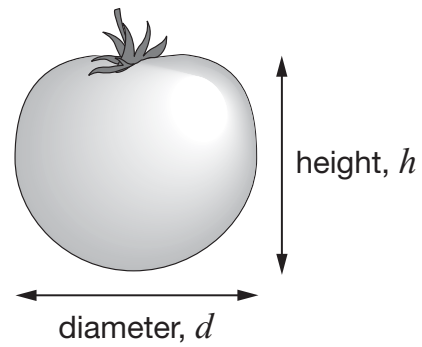

- (a) The diameter of a tomato of **type C** is **11 cm**.
 What would you expect its height to be?



_____ cm

1 mark

(b) The diameter of a different tomato is 3.2cm. Its height is 5.8cm.

Which of the three types of tomato is it most likely to be?

 A B C

Explain your answer.



1 mark

(c) Which type of tomato is most nearly **spherical** in shape?

 A B C

Explain your answer.



1 mark

(d) You can find the approximate volume of a tomato by using this formula:

$$V = \frac{1}{6} \pi d^2 h$$

V is the volume,
d is the diameter,
h is the height.

The diameter and the height of a tomato are both **3.5cm**.

What is the approximate volume of this tomato?



_____ cm³

2 marks



16. In a wildlife park in Africa, wardens want to know the position of an elephant in a certain area.

They place one microphone at each corner of a **4 km by 4 km** square.

Each microphone has a range of $3\frac{1}{2}$ km.

The elephant is **out of range** of microphones **A** and **B**.

Where in the square could the elephant be?

Show the region **accurately** on the diagram, and **label** the region **R**.

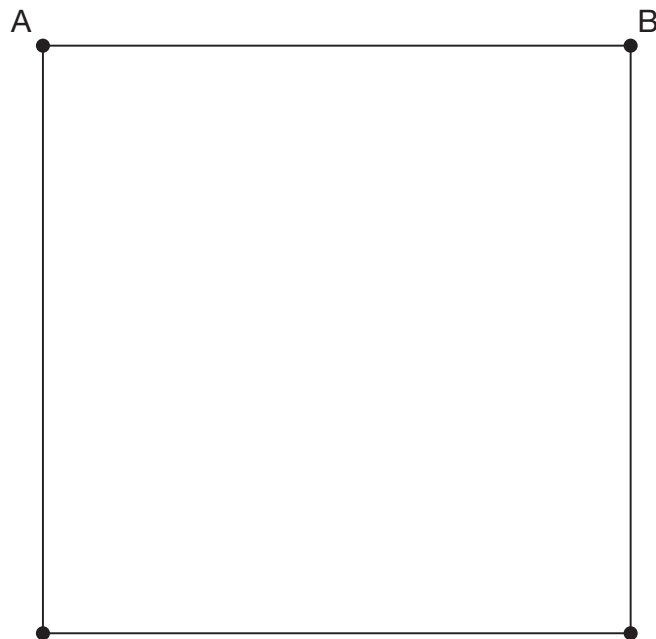

Scale
2 cm to 1 km

2 marks

17. Here are the rules for an algebra grid.

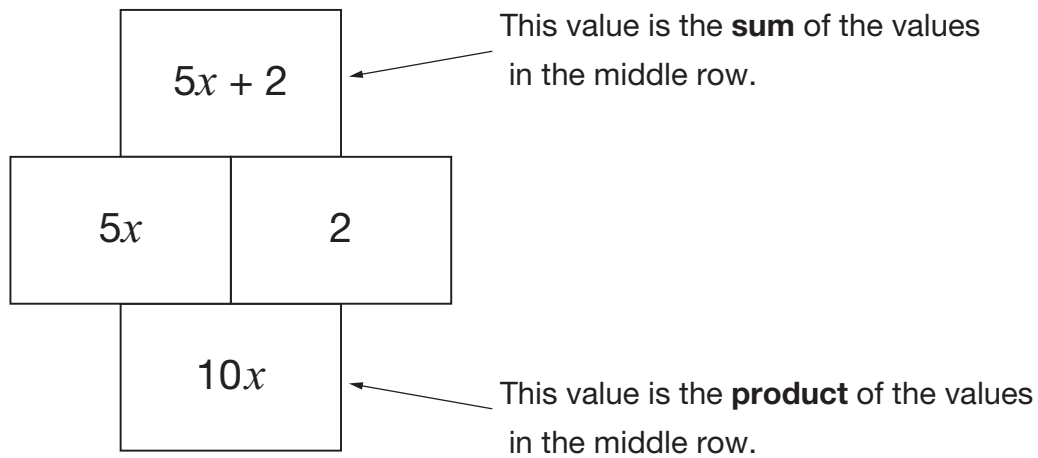

Use these rules to complete the algebra grids below.

Write your expressions as simply as possible.

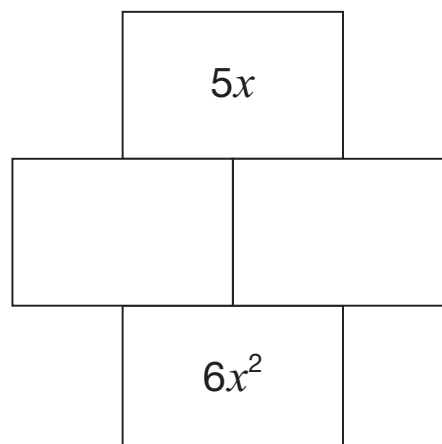
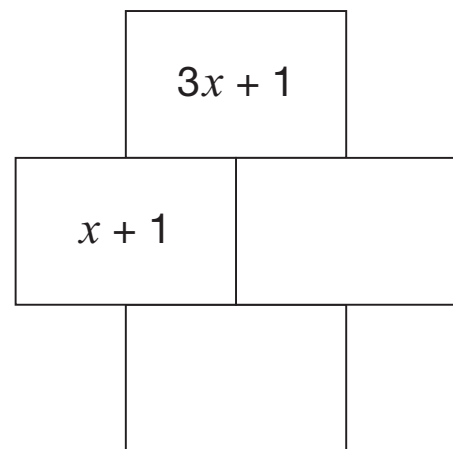
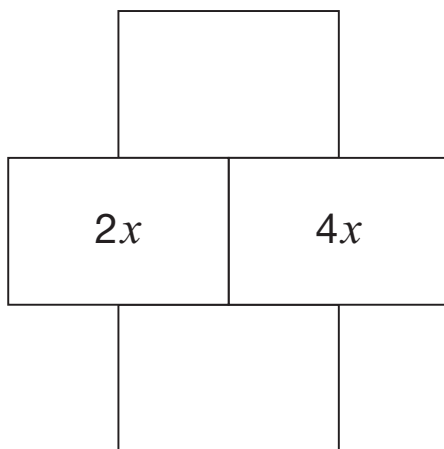

 3 marks



18. This shape is made of four congruent kites meeting at a point.

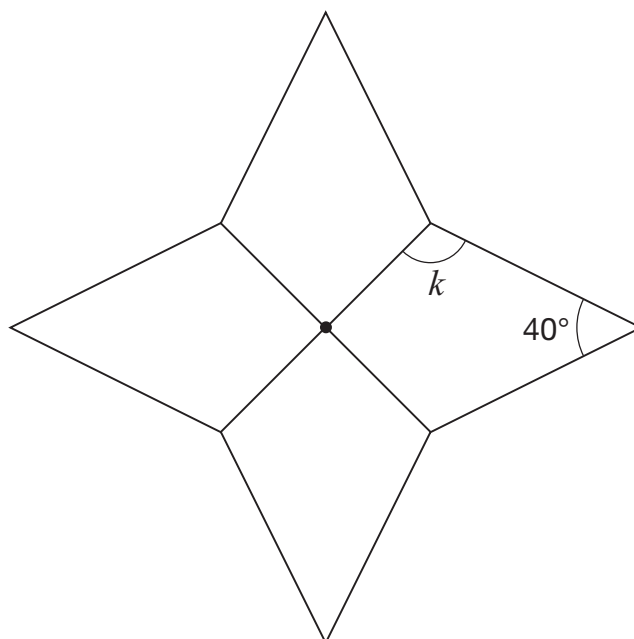

Not drawn accurately

Calculate the size of angle k



$$k = \text{_____}^\circ$$

2 marks

19. Look at the diagram of a cuboid.

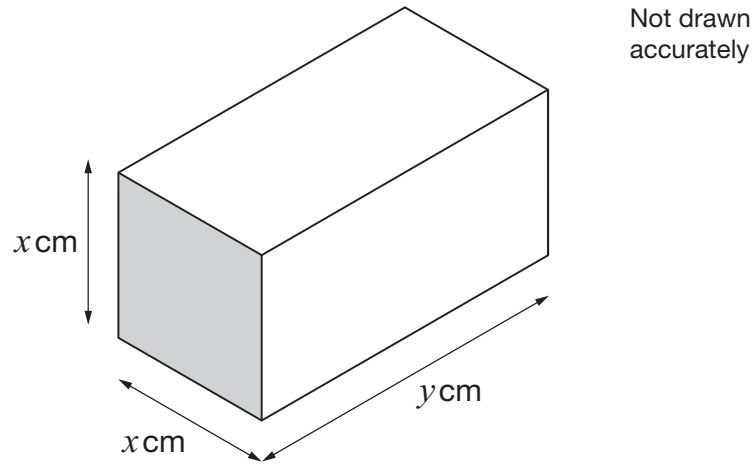

The **volume** of the cuboid is 100cm^3

What could the values of x and y be?

Give **two** possible pairs of values.



$x =$ _____ $y =$ _____

_____ 1 mark

$x =$ _____ $y =$ _____

_____ 1 mark



20. A pupil wants to investigate a report that Belgian one euro coins are biased in favour of heads.

Here is her plan for the investigation.

I will spin **20** Belgian one euro coins to give one set of results.

I will do this **10 times** to give a total of **200 results** to work out an estimated probability of spinning a head.

If this probability is **greater than 56%** my conclusion will be that Belgian one euro coins are biased in favour of heads.

The table shows the 10 sets of results.

| Number of each set of 20 coins that showed heads | | | | | | | | | |
|---|----|----|----|----|----|----|---|----|----|
| 10 | 13 | 11 | 11 | 12 | 12 | 11 | 9 | 10 | 11 |

Using the pupil's plan, what should her conclusion be?

You **must** show your working.



2 marks

21. The diagram shows a shaded rectangle.
It is divided into four smaller rectangles, labelled A, B, C and D.

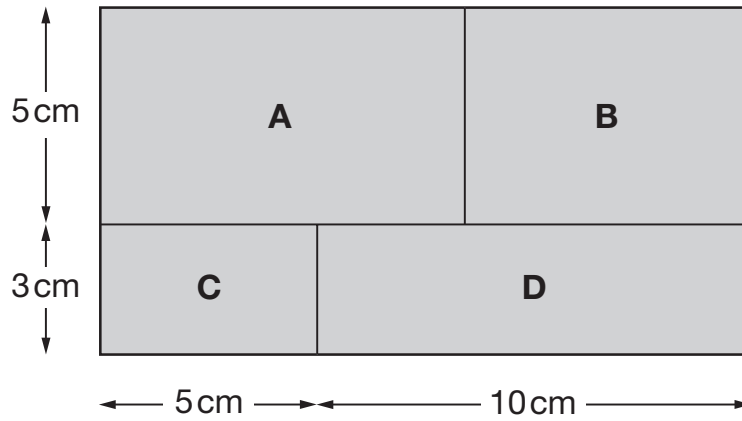

Not drawn accurately

The ratio of area **C** to area **B** is **1 : 2**

Calculate area A.



_____ cm^2

2 marks



- 22.** Field voles are small animals that do not live for very long.
A scientist recorded data on **1000** of these voles that were born on the same day.
The graph shows how many voles were still alive after a number of weeks.

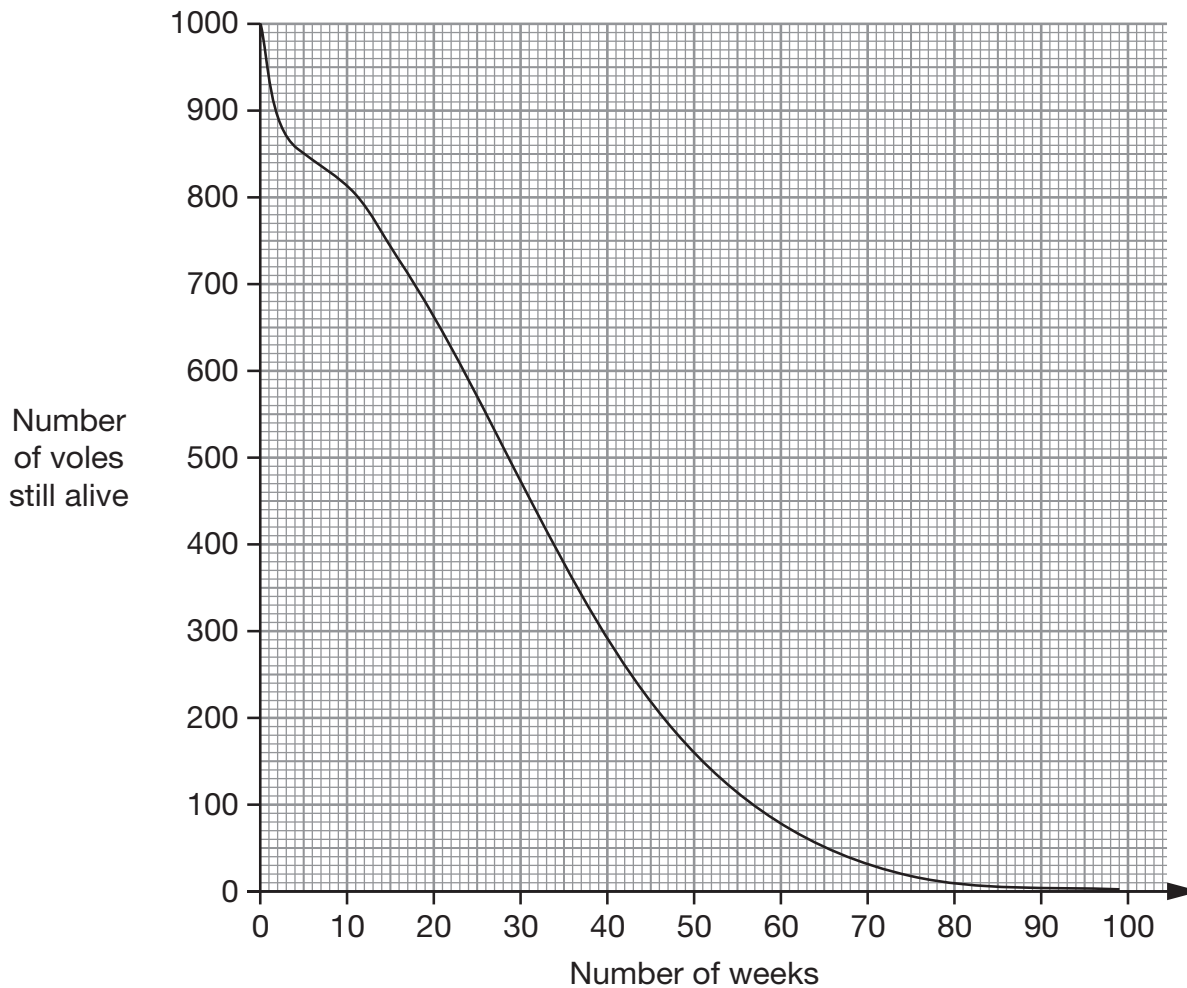

Use the graph to answer this question.

Estimate the probability that a field vole will live to be **at least 20** weeks old.



1 mark

END OF TEST



